

USER INSTRUCTIONS

MOD 600XB/1000

Modulift[®]
working between the hook and the load

The Modulift Spreader is modular in length. Every spreader consists of 1 pair of End Units & Drop Links, with intermediate struts that can be bolted into the assembly to achieve different spans. The MOD 600XB/1000 has an assembled span ranging from 2 metres to 26m in 0.5m increments.

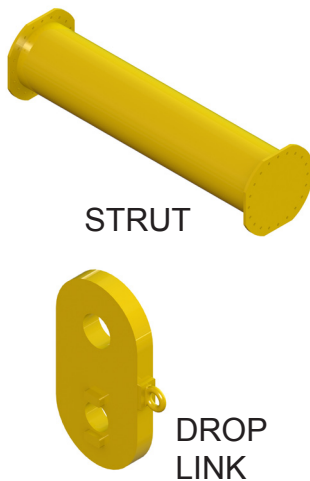
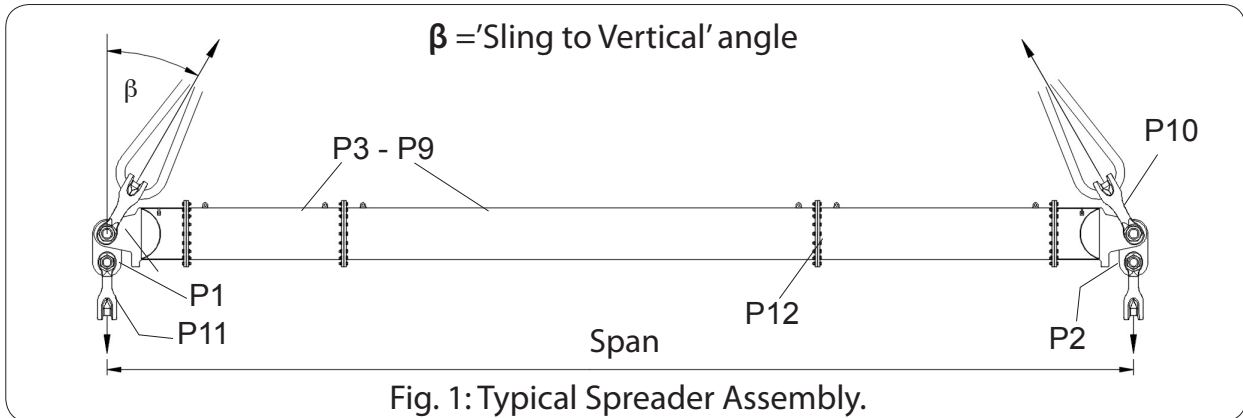
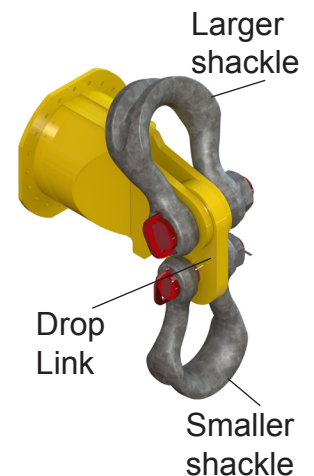

TABLE 1: COMPONENT LIST		
PART REF:	DESCRIPTION	WEIGHT / ITEM
P1	END UNIT WLL 500t	870kg
P2	DROP LINK WLL 500t	385kg
P3	6.0m STRUT	2665kg
P4	5.0m STRUT	2265kg
P5	4.0m STRUT	1865kg
P6	3.0m STRUT	1470kg
P7	2.0m STRUT	1070kg
P8	1.0m STRUT	675kg
P9	0.5m STRUT	475kg
P10	600t WIDE BODY SHACKLE	980kg
P11	500t WIDE BODY SHACKLE	780kg
P12	M24x90 Grade 10.9 HT BOLTS, NUTS & WASHERS	

END UNIT
SUB-ASSY



MOD 600XB/1000 - Beam Specification.

- Rated at 1000 tonnes SWL at 15 metres span (30° STV). See Load Table for SWL at longer spans.
- 'Sling to Vertical' angle, β , 45 degrees or less.
- End Units & Drop Links are rated at 500 tonnes WLL each (1000 tonnes combined capacity).
- **Bolt tightening torque: 250Nm.** Spanner size required: 36mm.
- Recommended additional equipment: Torque Wrench, Podger Spanner and Ring Spanner.



WARNING!

- Personnel using this system should be suitably trained, competent and have a clear understanding of Safe Slings procedures.
- The use of Modulift equipment must be in accordance with the procedures laid down in the 'Lifting Operations and Lifting Equipment Regulations 1998' (LOLER).
- NEVER EXCEED STATED SWL - ADHERE TO SWL IN TABLE 2, FOR PARTICULAR SLING ANGLE USED
- THE TOP SLING LENGTH IS CRITICAL TO THE SAFE USE OF THE SPREADER - ADHERE TO TABLE 2.
- Ensure Drop Links hang down, and smaller shackles are connected to bottom hole of Drop Link.
- Do not under any circumstances hang load(s) from the tube or flanges - the spreader is designed for axial compression - not bending.

MODULIFT UK LTD ·

t.+44(0)1202 621511 e. sales@modulift.com www.modulift.com

USER INSTRUCTIONS MOD 600XB/1000

Modulift[®]
working between the hook and the load

TABLE 2: Load v Span.

45° STV			Recommended Configuration EU - End Unit (1m) STV = 'SLING TO VERTICAL' ANGLE, β							30° STV		
Span /m	SWL /t	Min Top sling Length /m	EU	EU	EU	EU	EU	EU	EU	Span /m	SWL /t	Min Top sling Length /m
2	575	1.0	EU	EU						2	1000	2
3	575	2.0	EU	1	EU					3	1000	3
4	575	2.5	EU	2	EU					4	1000	4
5	575	3.5	EU	3	EU					5	1000	5
6	575	4.0	EU	3	1	EU				6	1000	6
7	575	4.5	EU	3	2	EU				7	1000	7
8	575	5.5	EU	6	EU					8	1000	8
9	575	6.0	EU	6	1	EU				9	1000	9
10	575	7.0	EU	6	2	EU				10	1000	10
11	575	7.5	EU	6	3	EU				11	1000	11
12	575	8.5	EU	3	6	1	EU			12	1000	12
13	575	9.0	EU	3	6	2	EU			13	1000	13
14	575	9.5	EU	6	6	EU				14	1000	14
15	575	10.5	EU	6	6	1	EU			15	1000	15
16	559	11.0	EU	6	6	2	EU			16	977	16
17	514	12.0	EU	6	6	3	EU			17	899	17
18	469	12.5	EU	1	6	6	3	EU		18	821	18
19	427	13.0	EU	2	6	6	3	EU		19	749	19
20	391	14.0	EU	6	6	6	EU			20	688	20
21	354	14.5	EU	6	6	6	1	EU		21	623	21
22	320	15.5	EU	6	6	6	2	EU		22	565	22
23	289	16.0	EU	6	6	6	3	EU		23	512	23
24	260	17.0	EU	1	6	6	6	3	EU	24	461	24
25	234	17.5	EU	2	6	6	6	3	EU	25	416	25
26	209	18.0	EU	1	2	6	6	6	3	EU	373	26



The rigger must ensure that there is a clearance between the sling end fitting and the end unit as shown.

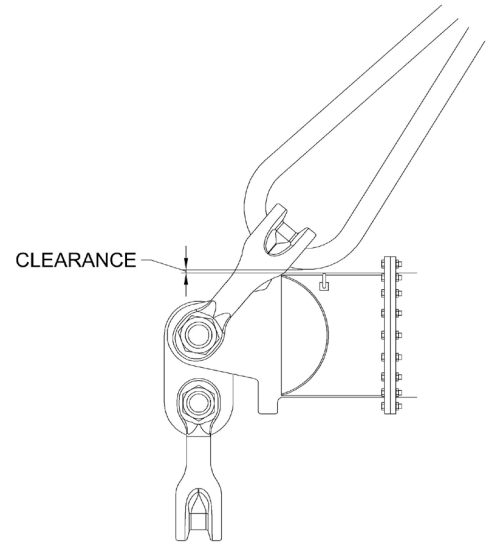

- Max number of struts allowed in spreader assembly: 6
- Assemble longer struts in the centre of the spreader configuration
- Sling angle is crucial to safe use of spreader

To calculate the SWL at intermediate spans utilising the 0.5m strut, round up the span to the next longest span in Table 2, and use the stated SWL.

Recommended top sling types: Textile slings, cable laid wire rope slings or grommets. It is strongly recommended that a sling angle of 30° STV or less is used, to always ensure clearance between the sling and end unit.
Note: Lengthening the slings can give greater clearance. Refer to Modulift supplier if in doubt.

ASSEMBLY PROCEDURE.

1. Check the ID plates on each Modulift component to ensure the correct size is used.
2. Lay out the Struts and End Units in the correct configuration (see table 2), laid on flats to prevent rolling.
3. Check that all pairs of flanges are clear from debris, sand etc. before connection.
4. Bolt the components together using bolts, nuts & washers provided. Tighten the bolts to a torque as shown overleaf, 20 bolts per connection*.
5. Place drop link inside the jaw of an end unit, with the larger hole of drop link lined up with the End Unit hole.
6. Place a top sling onto the body of a top shackle, and put jaw of top shackle over the end unit jaw.
7. Put top shackle pin through shackle, end unit jaw and drop link, and repeat for other spreader beam end.
8. Attach free ends of top slings to crane hook.
9. Attach lower slings and shackles to lower holes of drop links, and attach them to the load to be lifted.
10. **The assembled spreader beam and lifting rig must be thoroughly checked by a competent person prior to lifting.**

DO'S & DON'TS

- Do ensure to load the spreader through the drop links only. i.e. adhere to Fig. 1.
 - Do keep the loaded spreader clear of obstacles - any contact could cause beam failure.
 - Do ensure correct use of appropriate top slings, do not twist any slings unnecessarily.
 - Do not hang any load from the spreader tube or flanges.
 - Do not exceed stated SWL for that particular span - adhere to table 2.
 - Do not rig the lower slings more than 6 degrees from vertical.
 - When moving or positioning long struts or assemblies use tag lines to control movement.
 - Individual components can be heavy and extreme care must be taken if manual handling.
- *The number and grade of bolts is critical for the safe use of the spreader particularly at longer spans



Should you find your equipment is no longer of use, please dispose of in a responsible manner. Please contact Modulift if you need further guidance.